

Features

- High efficiency up to 95%
- THD <15%
- Output current adjustable via potentiometer or DIP switch
- DALI-2 intelligent control; supports logarithmic dimming and linear dimming
- Dim to off without afterglow
- Surge protection: L-N: 6kV & L/N-GND: 6kV
- All-round protections: over temperature protection, over voltage protection and short circuit protection
- Flicker free
- IP65



Application

- Highbay light

Descriptions

LF-FHB120YK/BK is a constant current LED driver featuring high efficiency, high PF and low THD. There is a potentiometer or a DIP switch on the side of LED driver used for adjusting the output current (power).

Product Model

LF - FHB 120 YK/BK

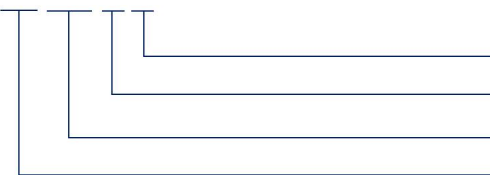

- BK: DALI (via DIP switch)
- YK: DALI (via potentiometer)
- 120: output power: 120W
- F: non-isolated design; HB: for highbay light

■ Electrical Characteristics

Model		LF-FHB120YK/BK			
Output	Output Current	Adjustable via potentiometer (YK)			
		250-500mA (default setting: 480mA)			
		Adjustable via DIP switch (BK)			
		250mA	330mA	420mA	500mA (default setting)
	Output Voltage	180-260Vdc (LED)			
	Output Power	120W max. @108-277Vac			
	Modulation Depth	<0.5% @full load			
	Current Tolerance	±8%			
	Startup Time	120Vac <2S; 230Vac <1.5S			
Temperature Drift	±3% @Ta 25~60°C				
Input	Input Voltage	100-277Vac (voltage limit: 90-305Vac)			
	DC Input Voltage	141-276Vdc			
	Input Current	1.6A max.			
	PF	≥0.95/230Vac @full load			
	THD	≤15% @full load			
	Efficiency	92.5%/120Vac @full load; 94%/230Vac @full load			
	Inrush Current	<80A/350uS @230Vac			
	Standby Power Consumption	≤0.5W @220Vac			
Protections	Surge	L-N: 6kV (2Ω), L/N-PE: 6kV (12Ω)			
	Open Circuit	Open circuit voltage≤310Vdc			
	Short Circuit	≤15W The LED driver will recover by itself and will not be damaged even in the state of short circuit for a long time.			
Environment Descriptions	Operating Temperature	-40°C~+60°C			
	Operating Humidity	0~95%RH (no condensation)			
	Storage Temperature/ Humidity	-40°C~+80°C (6 months in Class I environment); 0~95%RH (no condensation)			
	Atmospheric Pressure	86-106kPa			

■ Electrical Characteristics

Safety and EMC	Certifications	TUV-ENEC, CE, CB, RCM, SAA, CCC
	Withstanding Voltage	L-N/PG: 1.5kVac, <5mA, 60S; L-N/DALI: 3kVac, <5mA, 60S; DALI/PG: 500Vac, <5mA, 60S
	Safety Standards	ENEC: EN61347-1: 2015, EN61347-2-13: 2014/A1: 2017, EN62384 2016/A1: 2009 CE-LVD: EN61347-2-13: 2014/A1: 2017, EN61347-1: 2015, EN62493: 2015 CB: IEC61347-1: 2015, IEC61347-2-3: 2014, IEC 61347-2-13: 2014/AMD1: 2016 SAA: AS 61347.2-13: 2018 RCM: AS 61347.2-13: 2018 CCC: GB19510.1-2009, GB19510.14-2009
	EMI	CE-EMC/RCM: EN55015, EN61000-3-2, EN61000-3-3 CCC: GB/T17743, GB17625.1, GB17625.2
	EMS	Complies with IEC61000-4-2, 3, 4, 5, 6, 8, 11, 12; IEC61547 CE-EMC/RCM: EN61000-4-2, 3, 4, 5, 6, 11 CCC: GB/T17626.2, 3, 4, 5, 6, 11
	Ringing Wave	4kV
	ESD	Air 8kV, touch 4kV
	Other Parameters	IP Rating
RoHS		RoHS 2.0 (EU) 2015/863
DALI Standard		IEC 62386-101 102 207: DALI 2.0
Compatibility of DALI Dimming		Please pay attention that the LED driver match DALI master and applicative DALI master brands: Yuanhao Master, Simon Master, Philips Master DDBC120-DALI, OSRAM Master, Helvar Master 905 Router, Tridonic Master and HDL MC64-DALI431 Master.
Warranty Condition		5 years (Tc≤82°C)
MTBF		>1000Hours@Telcordia SR-332 Issue4
Testing Equipment	Digital power meter: CHROMA66202, oscilloscope: Tektronix DPO3014, DC electronic load: M9712B, LED board, constant temperature and humidity chamber; Everfine EMS61000-5B: Everfine EMS61000-4A, spectroanalyzer: KH3935, hi-pot tester: TH9201B, flicker tester (flicker-free coefficient test) 60N-01, etc.	
Testing Remark	If there are no special remarks, the above parameters are tested at the ambient temperature of 25°C, humidity of 50%, full load and input voltage of 230Vac.	

■ **Electrical Characteristics**

Additional Remarks	<ol style="list-style-type: none"> 1. It is recommended that user install over voltage protection, under voltage protection and surge protection devices in the power supply circuits of light fixtures to ensure electricity safety. 2. The PC cover, casing and end cap for assembling the LED driver in the light fixture must meet the fire rating of UL94-V0 or above. 3. The LED driver used in combination with the end device is one of the accessories of the whole light fixture, and the EMC of the whole light fixture is not only susceptible to the driver itself, but to the LED light fixture and the whole light fixture's wiring. Thus, the manufacturer of LED light fixture should re-confirm the EMC of the whole light fixture before the whole light fixture is finished. 4. It is suggested that user use a slotted screwdriver or a Phillips to adjust the output current of LED driver in case that the potentiometer is damaged (the screwdriver should have good insulation at the head, body and handle, and the screwdriver with a 2mm head is recommended as well; what's more, please pay attention that the intensity of torque not exceed 500g.cm). 5. When using the LED driver, please pay attention that the total output power not exceed the maximum rated output power, otherwise the warranty service of LED driver would be failed. 6. When conducting withstanding voltage test on LED driver, please short-circuit the input wire L and N; the positive electrode and negative electrode of the output wire; the positive electrode and negative electrode of the dimming wire and AUX power supply. 7. Please fully inspect the withstanding voltage ability of LEDs and aluminum substrates and the value shall >2.5kVac.
---------------------------	---

■ **Qty & Parameters of Driver (the same model) a Circuit Breaker Configures**

Item	Peak Inrush Current (Ipeak)	Half-peak Inrush Time (Twidth)
Input voltage 120Vac	39.2A	63.2uS
Input voltage 230Vac	63A	144uS

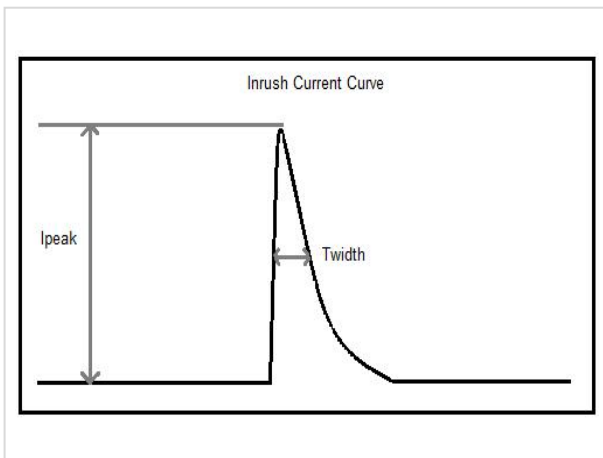

Qty of Driver a Circuit Breaker Configures (input voltage: 230Vac)		
Type	Rating	Qty of Driver
B	10A	9 pcs
	13A	12 pcs
	16A	14 pcs
	20A	18 pcs
	25A	23 pcs
C	10A	12 pcs
	13A	15 pcs
	16A	18 pcs
	20A	23 pcs
	25A	29 pcs

■ Product Characteristic Curves

PF Curve

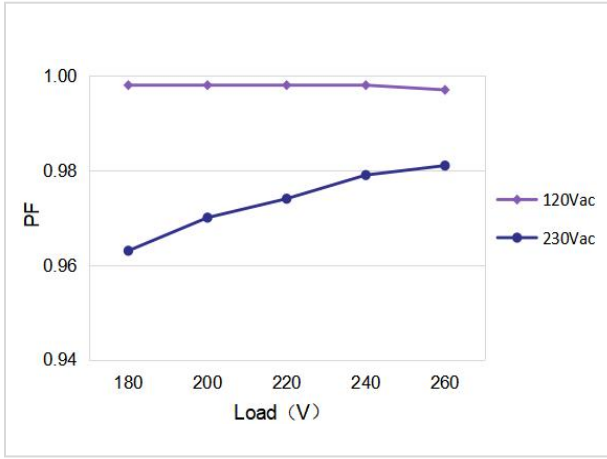

Efficiency Curve

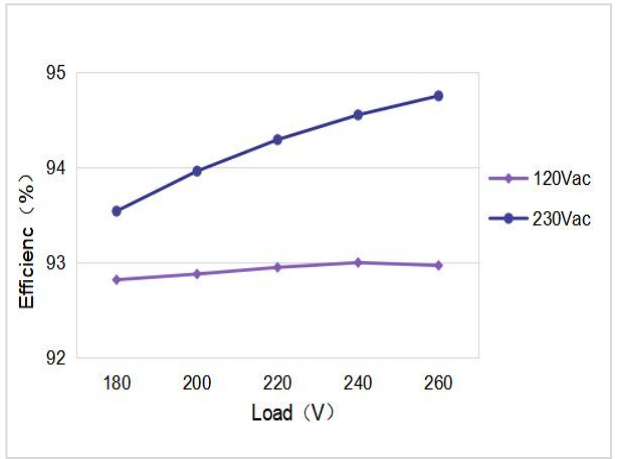

Load Derating Curve

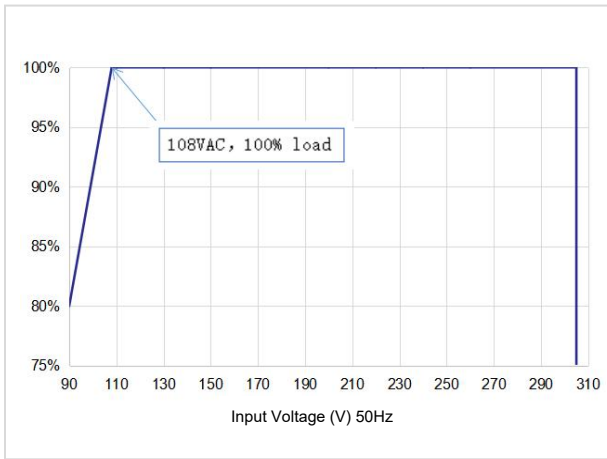

Power Curve

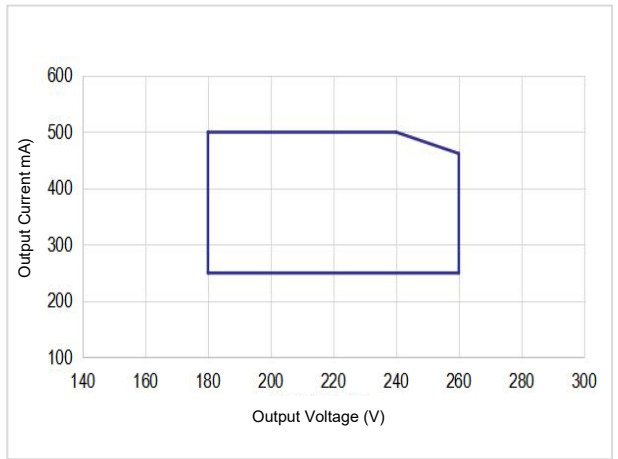

Lifetime Curve

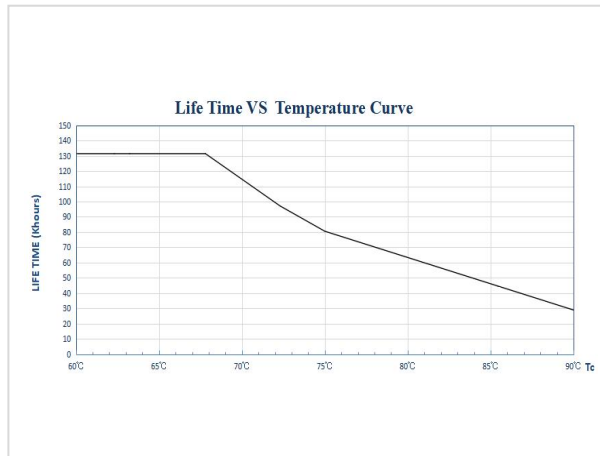

■ **Dimming Operation Instructions**

Output current adjustable via built-in potentiometer (YK)

Parameter	MIN	TYP	MAX	Remark
Output Current	250mA	-	500mA	The total output power should NOT exceed 120W

Output current adjustable via built-in DIP switch (BK)

Current Adjustment Reference Table				
Output Current	1	2	3	Remark
250mA	-	-	-	The total output power should NOT exceed 120W
330mA	-	-	ON	
420mA	-	ON	-	
500mA	ON	-	-	

DALI Dimming Operation

- Factory settings: 100% luminance & logarithmic dimming curve.
- Connect DALI signal to DA1 and DA2.
- DALI protocol includes 16 groups and 64 IP addresses
- DALI dimming depth: 10% (lout) (typical value)

Wiring Diagram of DALI Dimming

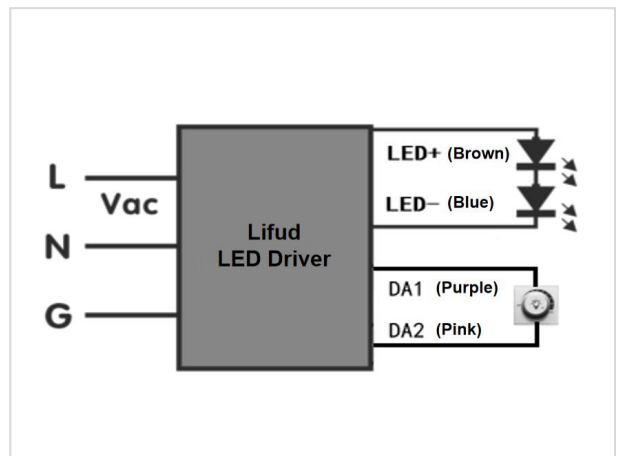

■ **Dimming Operation Instructions**

DALI Logarithmic Dimming Curve

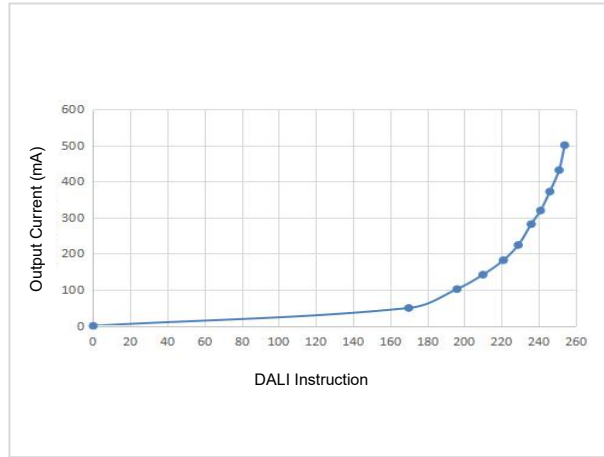

Input: 230Vac; output: 240Vdc/500mA (this data is measured by Lifud DALI dimmer and the chart is for reference only)

■ **Structure & Dimensions (unit: mm)**

Wire Specifications

Type	Input Wire	Output Wire	Dimming Wire & AUX Output
YK/BK	3*1.0mm ² Φ 7.2±1mm	2*1.0mm ² Φ 6.8±1mm	2*22AWG Φ 4.5±1mm
Color	AC-L Brown; AC-N Blue; PG Yellow & Green	LED+ Brown; LED- Blue	DA1 Purple; DA2 Pink
Length	300±10mm (L1)	200±8mm (L2)	280±8mm (L3)
			200±8mm (L4)
Peeled	40±4mm (X1)	35±4mm (X2)	40±4mm (X3/X4)
Tinned	10±1.5mm (Y1)	10±1.5mm (Y2)	10±1.5mm (Y3/Y4)

Overall Appearance

Description	Symbol	Unit (mm)
Casing Diameter	A	Φ127.3
Diameter of Fixed Screw Hole	4-B	Φ6.4
Diameter of Assembly Hole	W	113
Ring's Hole	Z	M10*1.5
Casing Height	H	61.4

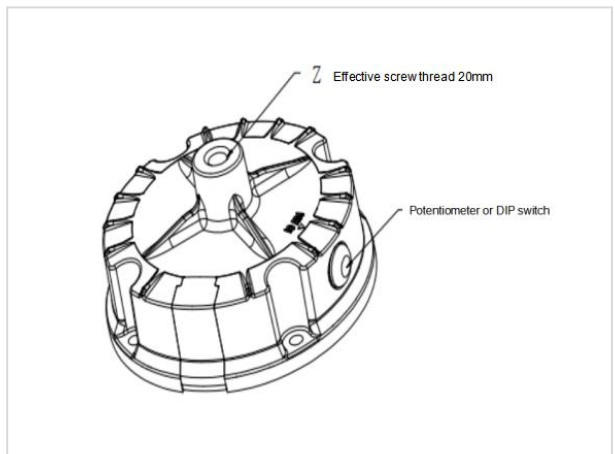

■ **Structure & Dimensions (unit: mm)**

Overall Appearance

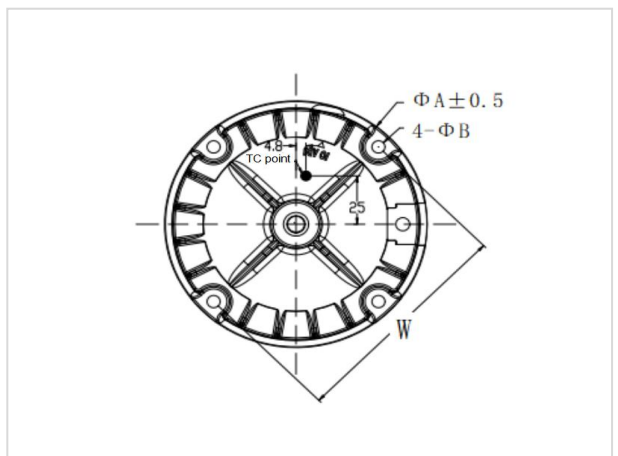
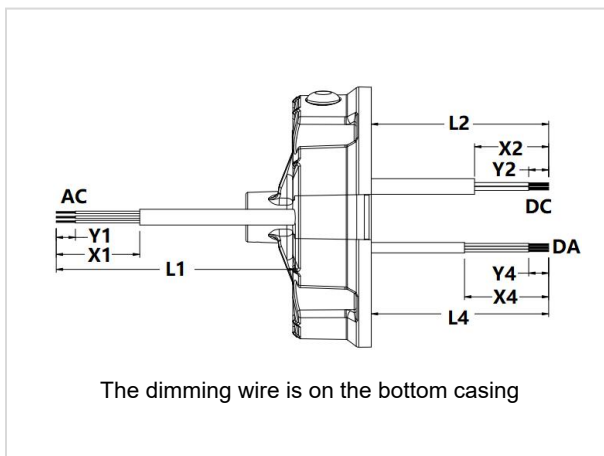
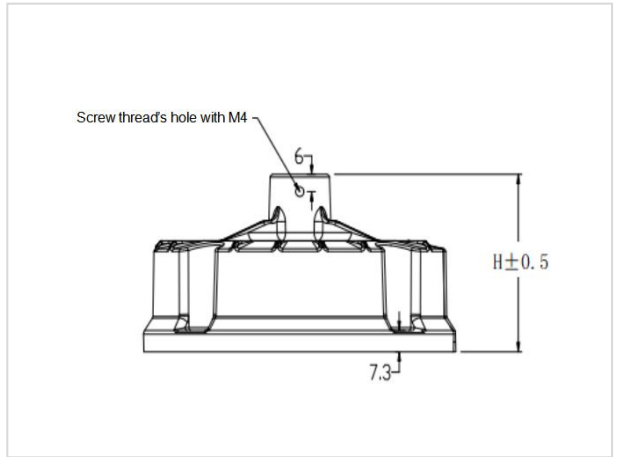
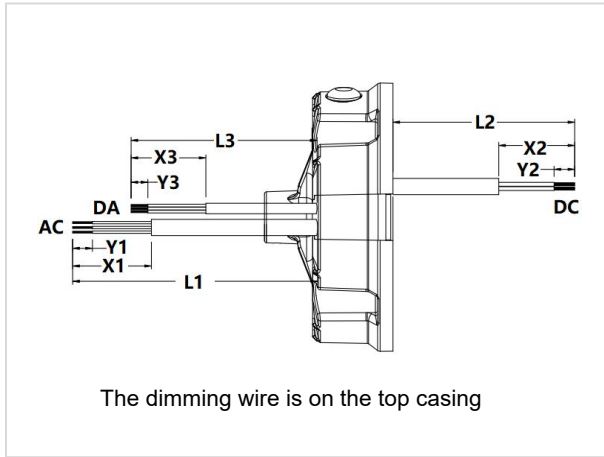

Remark: the external casing with a bracket hole is selectable.

■ **Packaging Specifications**

Model	LF-FHB120YK/BK
Carton Size	570*380*175mm (L*W*H)
Quantity	15 pcs/layer; 1 layer/ctn; 15 pcs/ctn
Weight	0.722±0.1 kg/pc; 14.16±1.2 kg/ctn

■ **Transportation and Storage**

1. Transportation

- Suitable transportation means: vehicles, boats and aeroplanes.
- In transit, it is necessary to prepare awnings for rain or sun protection. Moreover, please keep civilized loading and unloading to prevent the vibration or impact of LED driver as much as possible.

2. Storage

- The storage of LED driver shall conform to the standard of Class I environment. When using LED drivers which have been stored for more than 6 months, please re-test them firstly. Do not use them unless they are tested to be qualified.

Cautions

- Please use Lifud LED driver according to its parameters in the specification, otherwise the LED driver may malfunction.
- Using any incompatible light fixtures or those that have not been certified may cause fire, explosion or other risks.
- Man-made damage is beyond the scope of Lifud warranty service.

Remark: Lifud Technology Co., Ltd. reserves the right to interpret any contents of this specification.