

1. Product Description



Electrical type: isolated LED driver for Class I LED light fixtures

Percent flicker: $\leq 1\%$

Function: 220-240VAC, flicker free

Feature: high PF, high efficiency, low THD, flicker free

Application: indoor office lighting, commercial lighting & decorative lighting

Warranty: 5 years (Please refer to the warranty condition.)

Certification:



2. Electrical Specification

Model		LF-GMR075YV024A	LF-GMR075YV012A	
Output	Output Voltage	24VDC	12VDC	
	Output Current	3125mA max.	6250mA max.	
	Ripple Voltage	< 1V		
	Voltage Accuracy	24 \pm 0.5V	12 \pm 0.3V	
	Start-up Time	<0.5S @230Vac		
	Temperature Drift	$\pm 10\%$		
	Line Regulation	$\pm 5\%$		
Input	Line Regulation	$\pm 5\%$		
	Rated Input Voltage	220-240Vac (voltage limit: 200-264Vac)		
	Input Frequency	47Hz-63Hz		
	Input Current	0.6A Max		
	Power Factor		$\geq 0.96/200Vac$	
			$\geq 0.97/230Vac$	
			$\geq 0.96/264Vac$	
	THD	$\leq 20\%$		
	Efficiency		$\geq 88.5\%/200Vac$	
			$\geq 88.5\%/230Vac$	
		$\geq 88\%/264Vac$		
In-Rush Current	<80A/500uS@230Vac			
Stand-by Power Consumption	$\leq 1W@230Vac$			
Protective Feature	Over-Voltage	$\leq 35V$ (Cut off the output voltage. Auto-recovery)	$\leq 16V$ (Cut off the output voltage. Auto-recovery)	
	Over-Load	108%-150% (auto-recovery)		
	Short-Circuit	Hiccup mode (auto-recovery)		

Environment Condition	Working Temperature	-30°C ~ +50°C
	Working Humidity	20-90%RH (no condensation)
	Storage Temperature/ Humidity	-40°C ~ +80°C (6 months under the class I environment); 10-90%RH (no condensation)
	Atmospheric Pressure	86-106KPa
Safety & Norm	Certification	TUV-CE, RCM, SAA, CB, CCC
	Withstanding Voltage	I/P-O/P: 3.75KVac, <5mA 60S; I/P-FG: 1.6KVac, <5mA 60S; O/P-FG: 0.5KVac, <5mA 60S
	Insulation Resistance	I/P-O/P, I/P-FG, O/P-FG: 500VDC, >100MΩ
	Surge Rating	Conform to IEC61000-4-5 (L-N:1KV; L/N-PG:2KV)
	EMI	Conform to EN55015, EN61000-3-2
	EMS	Conform to EN61000-4-2, 3, 4, 5, 6, 8, 11; EN61547
Others	IP Rating	IP20
	Warranty Condition	5 years (TC≤ 75°C)
Testing Equipment	AC power source: CHROMA6530, digital power meter: CHROMA66202, Oscilloscope: Tektronix DPO3014, DC electronic load: M9712B, LED strip, constant temperature and humidity chamber, lightning surge generator: Everfine EMS61000-5B, rapid group pulse generator: Everfine EMS61000-4A, spectroanalyzer: KH3935, hi-pot tester: TH9201B, stroboscope (flicker coefficient tester) 60N-01, etc.	
Testing Condition	Unless otherwise stated, the electrical parameters above, including the power factor, THD and efficiency, were tested under the ambient temperature of 25°C and humidity of 50%, input voltage of 230Vac and 90% load.	
Remark	<ol style="list-style-type: none"> 1. It is recommended that customers should install overvoltage and undervoltage protection devices and surge protection devices to ensure safety before connecting to electricity. 2. The PC cover, casing, end caps and other parts of the LED driver inside the LED light fixture must conform to the UL94 V-0 flammability standard or above. 3. As an accessory, the LED driver is not the only factor determining the EMC performance of the LED light fixture. The structure and the wiring of the light fixture are also relevant. Thus it's strongly recommended the LED light fixture manufacturer should re-confirm the EMC of the whole LED light fixture. 	

3. Product Lifetime Curve

The curve below illustrates the driver's lifetime data when its maximum casing temperature in an airtight space reaches 40°C, 50°C, 60°C, 70°C and 80°C.

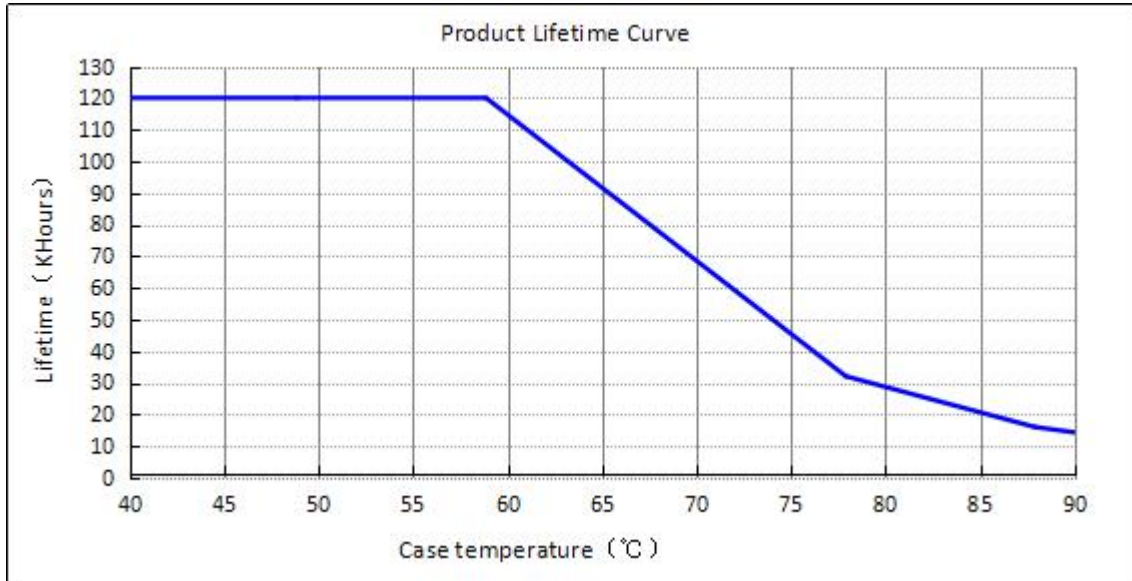

4. Dimension (Unit: mm; Tolerance: +0.5mm)

4.1 Dimension of the casing

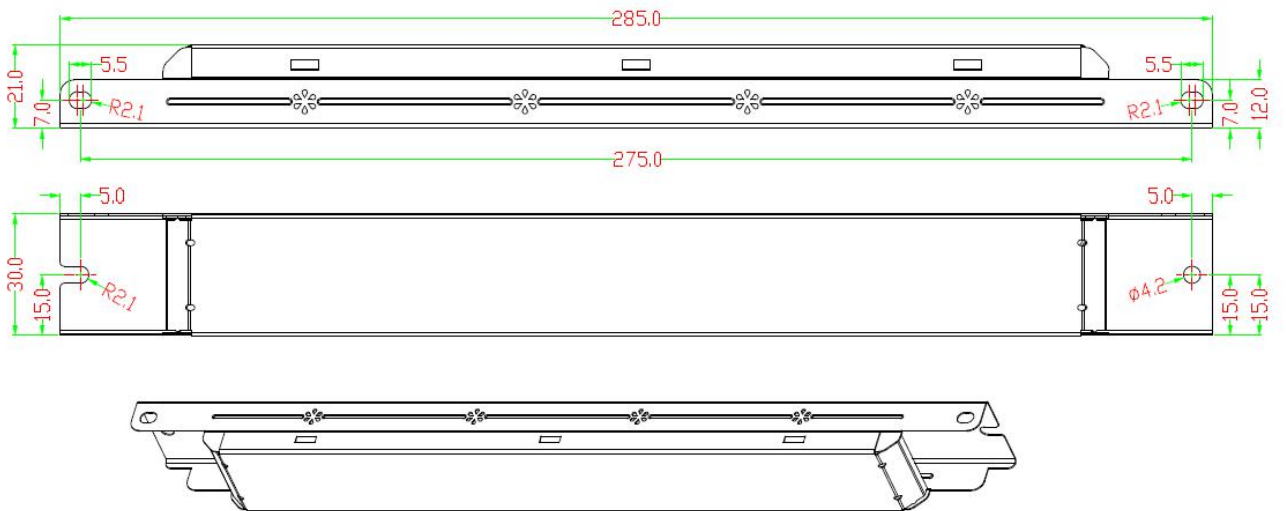

4.2 Dimension of the casing & the terminal covers

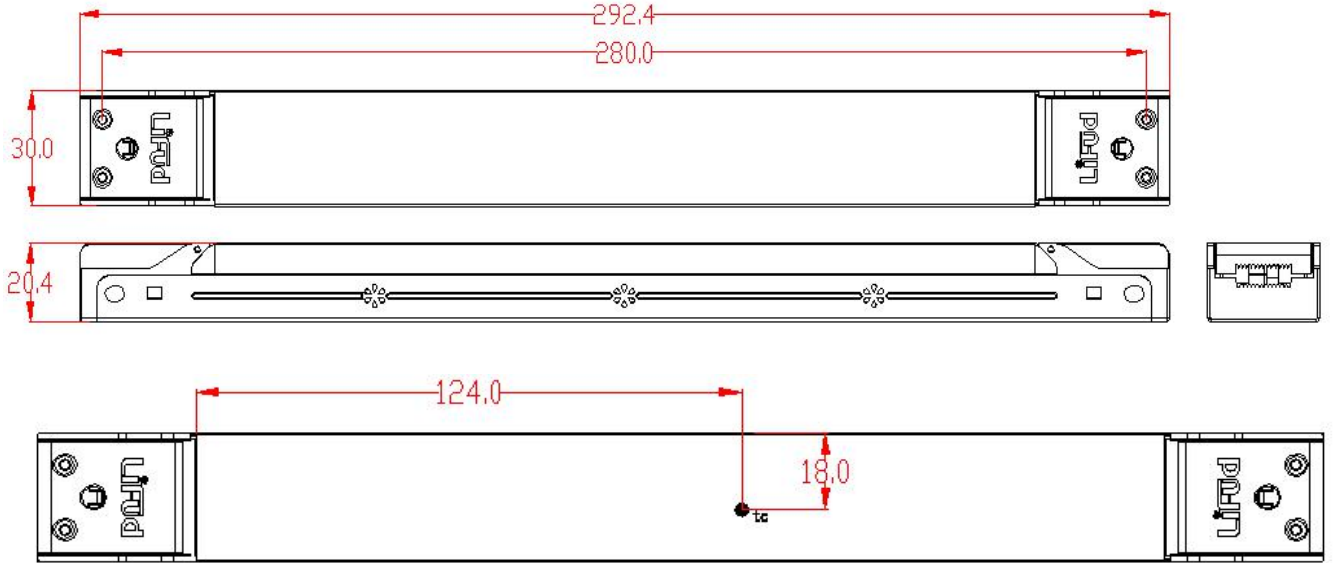

5. Wiring Diagram

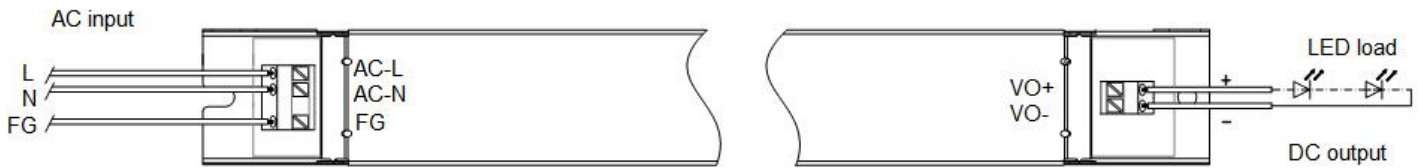

6. Package Specification

	Non-Individual Packaging	Individual Packaging
Box Size	385*285*210 mm (L*W*H)	
Quantity	6 pcs/layer; 6 layers/ctn; 36 pcs/ctn	8 pcs/layer; 6 layers/ctn; 48 pcs/ctn
Weight	0.265 kg±5%/pc; 9.7 kg±5%/ctn	0.265 kg±5%/pc; 12.67 kg±5%/ctn

7. Transportation & Storage

(1) Transportation

Transportation means: vehicles, boats and aircraft.

During transportation, there should be awnings for rain protection and sun protection. Civilized loading and unloading are required. There should be no severe vibration or impact.

(2) Storage

Storage in accordance with the provisions of the GB 3873-83. Products which have been stored for more than one year must be re-inspected. Use them only if they can pass the re-inspection.

8. Attention

- * Use this product according to the specifications, please. Otherwise there may be malfunction.
- * Use luminaires that have not been certified or are not compatible with the drivers may cause fire, explosion or other hazards.
- * Man-made damage is not covered by warranty.
- * Mind the withstanding voltage requirement for the aluminium substrate.

Remark: The final interpretation right of the contents of this data sheet belongs to Lifud Technology Co., Ltd.