

Features

- Full protection: short-circuit, over-load, no-load, reversing protection
- Wide application: compact size
- Triac Dimmable, maximum current: 400mA
- 5-year warranty (please refer to the warranty condition)

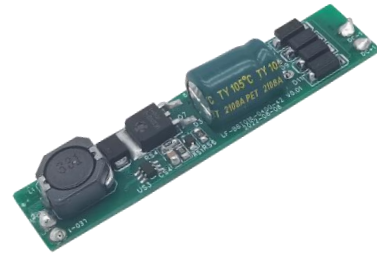

Applications

· Indoor office lighting · decorative lighting · commercial lighting · residential lighting

Descriptions

LF-BBT016-0400-42 is a 16W constant current LED driver with 3-in-1 Triac dimming function. Its input voltage is 48Vdc±5% and output current is up to 400mA. It features compact size, built-in design (inside the magnetic track box), high efficiency and smooth dimming.

Product Model

LF - BBT 016 - 0400 - 42



■ Electrical Characteristics

Model		LF-BBT016-0400-42
Output	Output Voltage	9-42V($V_{in}-V_o \geq 7V$)
	Output Current	400mA
	Output Power	16.8W max
	Flicker Index	IEC-Pst ≤ 1 , CIE-SVM ≤ 0.9 , Modulation Depth $\leq 1\%$ Complies with IEEE Std 1789-2015
	Current Tolerance	$\pm 8\%$
Input	Input Voltage	48Vdc $\pm 5\%$ (voltage input is neither positive nor negative)
	Input Current	0.45A max.
	Efficiency	$\geq 91\%$ (Load voltage and current: 42V, 400mA)
Protections	Short Circuit Protection	Auto-recovery
	Overload Protection	When the output voltage is exceeded, the output current drops, and the load is reduced to recover automatically.
	No Load Protection	No damage to driver (No-load voltage $\leq 59V$)
	Reversing Protection	Normal output when input is reversed
Environment Descriptions	Operating Temperature	-15°C - +60°C
	Operating Humidity	20-90%RH (without condensation)
	Storage Temperature/ Humidity	-30°C - +80°C (6 months in Class I environment); 10-90%RH (without condensation)
	Atmospheric Pressure	86-106kPa
Other Parameters	RoHS	RoHS 2.0 (EU) 2015/863
	Warranty	5 years ($T_a \leq 60^\circ C$)
Testing Equipment	Digital power meter: CHROMA66202, oscilloscope: Tektronix DPO3014, DC electronic load: M9712B, LED board, constant temperature and humidity chamber; Everfine EMS61000-5B; Everfine EMS61000-4A, spectroanalyzer: KH3935, flicker tester (flicker-free coefficient test) 60N-01, etc.	
Testing Remark	If there are no special remarks, the above parameters are tested at the ambient temperature of 25°C, humidity of 50%, full load and input voltage of 230Vac.	
Additional Remarks	<ol style="list-style-type: none"> 1. The PC cover, casing and end cap for assembling the LED driver in the light fixture must meet the fire rating of UL94-V0 or above. 2. Pay attention to waterproof, moisture-proof and electrostatic proof during the usage. 3. Pay attention to the insulation of between PCB boards and metal parts of the shell to avoid abnormalities. 	

■ **Product Characteristic Curves**

Output Current & Voltage Curve

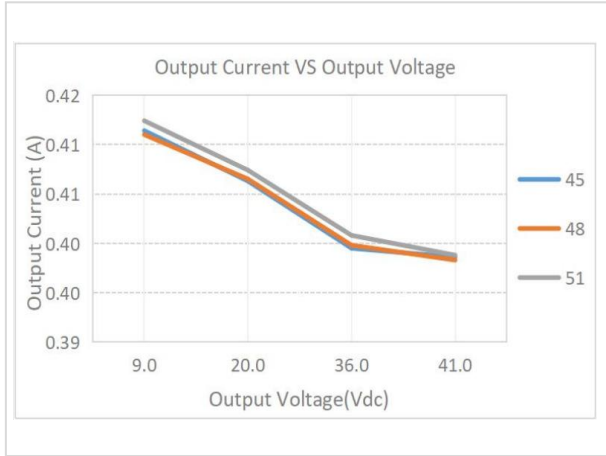

Efficiency Curve

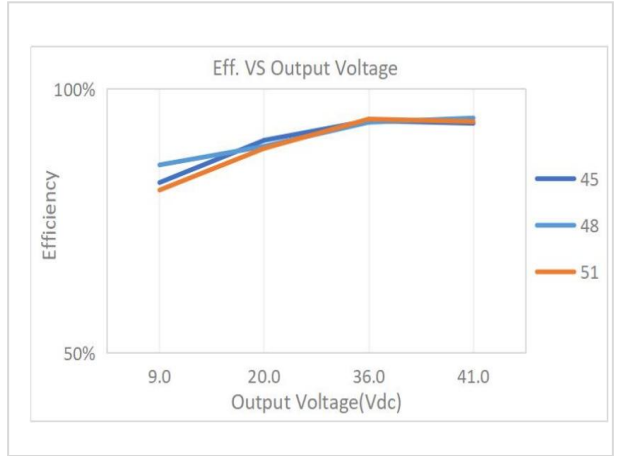

Dimming from min. to max.

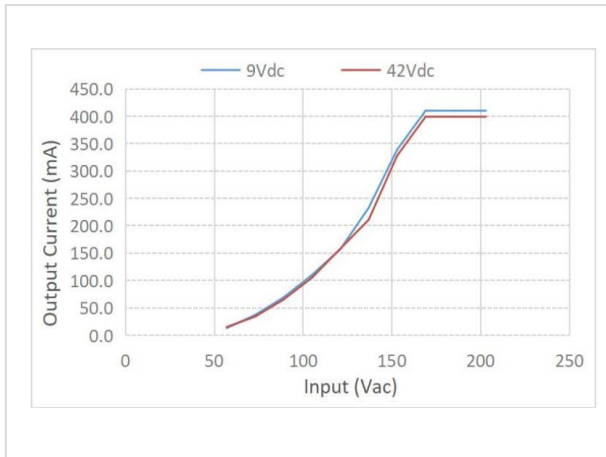

Dimming from max. to min.

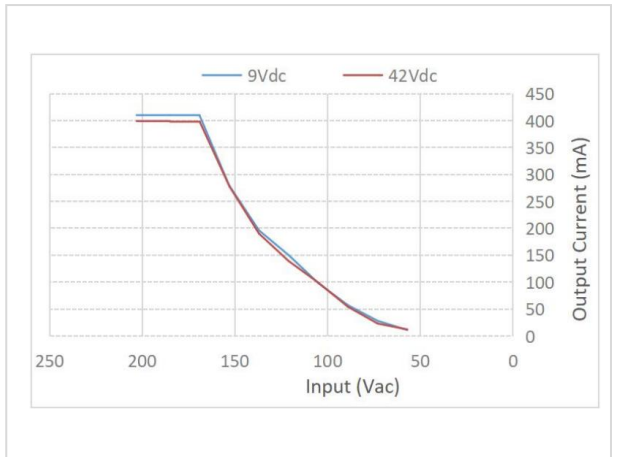

Remark: Input:48Vdc; output: 42VDC/400mA 9VDC/400mA (This data is measured by Lifud Triac dimmer and the chart is for reference only) When select signal converter, please make sure the output signal of the converter is smooth and stable without flicker, otherwise it will affect the dimming.

■ **Product Definitions**

INPUT	
48VIN	DC Input (Positive/negative electrode)
48VIN	DC Input (Positive/negative electrode)

OUTPUT	
LED+	Positive electrode output of LED driver
LED-	Negative electrode output of LED driver

■ **Structure and Dimensions (unit: mm)**

Appearance and dimensions

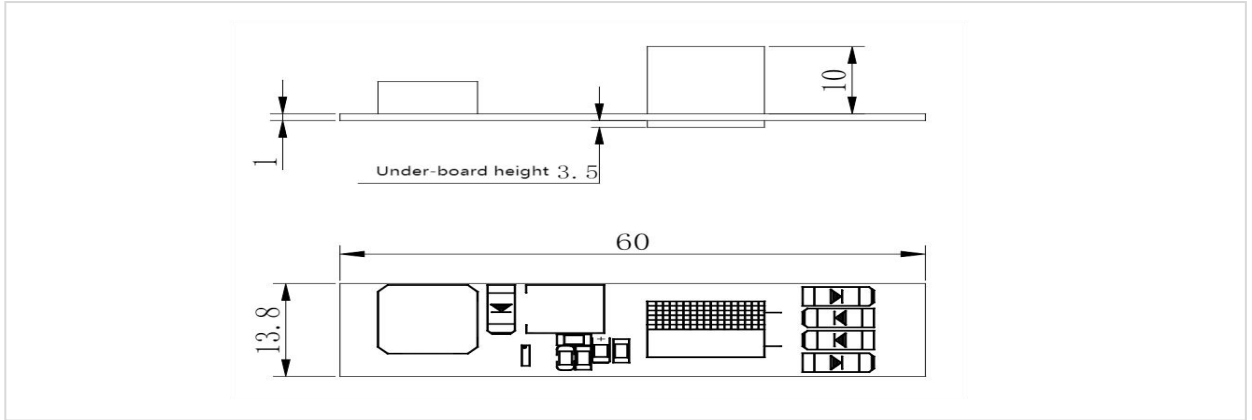

■ **Magnetic Triac Wiring Diagram**

1. Dimming with a decoder

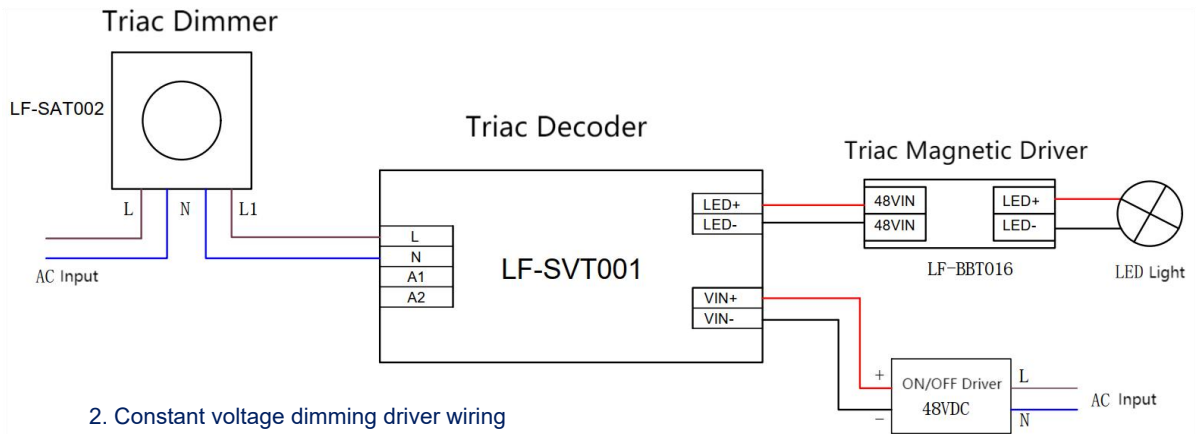

2. Constant voltage dimming driver wiring

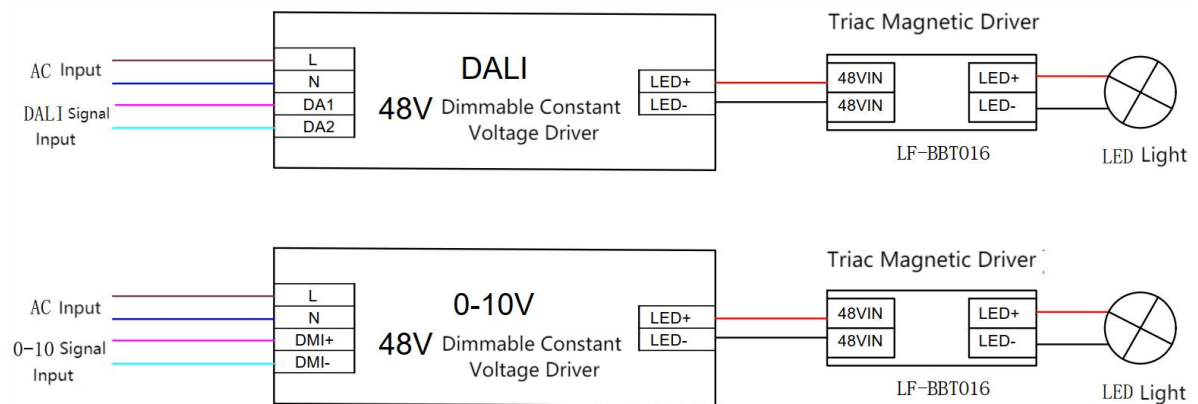

■ Packaging Specifications

Model	LF-BBT016-0400-42
Carton Size	385*285*210 mm (L*W*H)
Quantity	50 pcs/layer; 10 layers/ctn; 500 pcs/ctn
Weight	0.006 kg/pc; 4.3 kg/ctn

■ Transportation and Storage

1. Transportation

- Suitable transportation means: vehicles, boats and aeroplanes.
- In transit, it is necessary to prepare awnings for rain or sun protection. Moreover, please keep civilized loading and unloading to prevent the vibration or impact of LED driver as much as possible.

2. Storage

- The storage of LED driver shall conform to the standard of Class I environment. When using LED drivers which have been stored for more than 6 months, please re-test them firstly. Do not use them unless they are tested to be qualified.

Cautions

- Please use Lifud LED driver according to its parameters in the specification, otherwise the LED driver may malfunction.
- Using any incompatible light fixtures or those that have not been certified may cause fire, explosion or other risks.
- Man-made damage is beyond the scope of Lifud warranty service.

Remark: Lifud Tecnology Co., Ltd. reserves the right to interpret any contents of this specification.